



Product Portfolio

**Dneprovsk
Metallurgical Plant**

CONTENTS

Company profile	3
Products for transport applications	4
Subway conductor rails	5
Car building sections	5
Products for construction applications	6
Special I-beams for mine shafts reinforcement	7
Parallel flange channels	8
Inclined flange channels	9
Equal angles acc. to EN 10056-1:2017	10
Equal angles acc. to DSTU 2251:2018 (GOST 8509-93)	11
Products for industrial applications	12
Pit barring sections	13
Hot-rolled steel sections for shares	13
Semifinished products	14
Motor vehicle wheel rim sections	15
Certificates	16



Dneprovsk metallurgical plant

DMZ is a metallurgical enterprise and a member of the DCH Group.

Its core production facilities include the **medium-section rolling mill 550**. The mill produces a range of **specialized rolled products**, including **steel mine support props, contact rails for metro electrification systems, and rolled profiles for railcar manufacturing**.

The 550 rolling mill also manufactures **standard structural sections**, such as **parallel flange channels No. 8P-30P, U and UPE channels in accordance with European standards (EN)**, as well as **equal-leg angles No. 70-125**, and other rolled sections.



**PRODUCTS
FOR TRANSPORT
APPLICATIONS**

Subway conductor rails

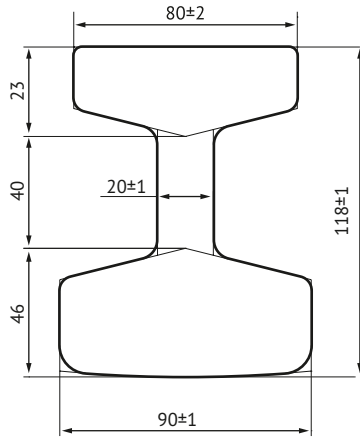

Rail type	Normative document for technical requirements	Steel grade	Normative document for chemical composition	Product length
PK	TU U 27.1-19305558-003:2009	M	TU U 27.1-19305558-003:2009	Specified length 6 and 12.5 m

Car building sections

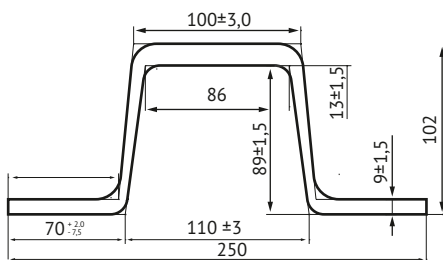

Car post

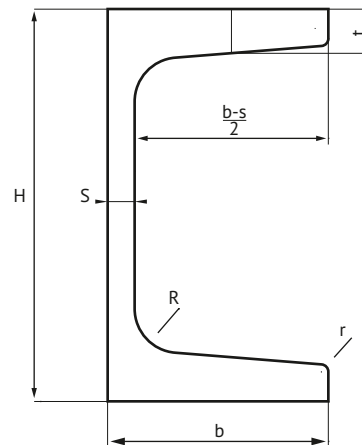

8B channel

Profile type	Normative document for technical requirements	Steel grade	Normative document for chemical composition	Product length
8B channel	DSTU 7551:2014 GOST 5267.1-90	09Г2С, 09Г2Д	DSTU 8541:2015 GOST 19281-2014	Specified length up to 12 m; random length
Car post	DSTU 7551:2014 GOST 5267.1-90			



**PRODUCTS
FOR CONSTRUCTION
APPLICATIONS**

Special I-beams for mine shafts reinforcement

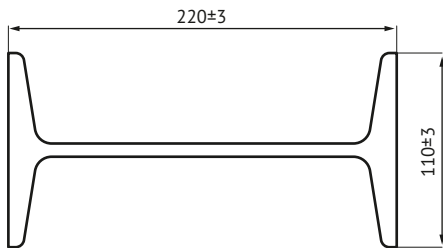

Profile type	Normative document for technical requirements	Steel grade	Normative document for chemical composition	Product length
22C	DSTU 8807:2018	Ст3пс/сп, 09Г2С	DSTU 2651:2005 GOST 380-2005 DSTU 8541:2015	Specified length 2-12 m



Parallel flange channels

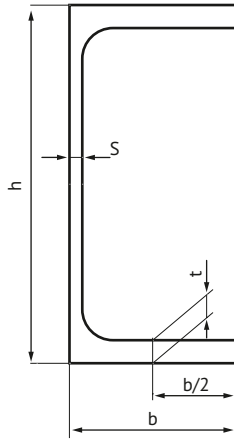

UPE-channel

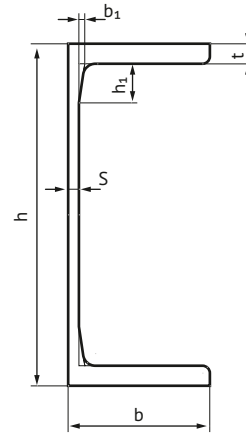

U-channel

Profile type	h	b	s	t	h1	b1	R	r	Weight of 1 m, kg
	Dimensions, mm								
8П	80	40	4,2	7,4	14	2,0	4	2,5	7,034
10П	100	46	4,3	7,6	14	2,0	4	3,0	8,580
12П	120	52	4,3	7,9	14	2,0	5	3,0	10,216
14П	140	58	4,4	8,2	16	2,4	5	3,0	12,066
16П	160	64	4,4	8,5	16	2,4	6	3,5	13,825
18П	180	70	4,5	9,2	16	2,4	6	3,5	16,164
20П	200	76	4,6	9,6	18	2,6	7	4,0	18,414
22П	220	82	4,6	10,0	18	2,6	7	4,0	20,527
24П	240	90	4,8	10,6	20	2,6	7	4,0	23,698
27П	270	95	5,9	10,6	20	2,6	8	5,0	27,810
30П	300	100	6,3	11,4	20	2,6	8	5,0	32,09

Profile type	Height, h	Flange width, b	Inner radius, r1	Wall thickness, s	Flange thickness, t	Weight of 1 m, kg
	Dimensions, mm					
UPE 80	80	50	10	4	7	7,90
UPE 100	100	55	10	4,5	7,5	9,82
UPE 120	120	60	12	5	8	12,1
UPE 140	140	65	12	5	9	14,5
UPE 160	160	70	12	5,5	9,5	17,0
UPE 180	180	75	12	5,5	10,5	19,7
UPE 200	200	80	13	6	11	22,8
UPE 220	220	85	13	6,5	12	26,6
UPE 240	240	90	15	7	12,5	30,2
UPE 270	270	95	15	7,5	13,5	35,2
UPE 300	300	100	15	9,5	15	44,4



Inclined flange channels

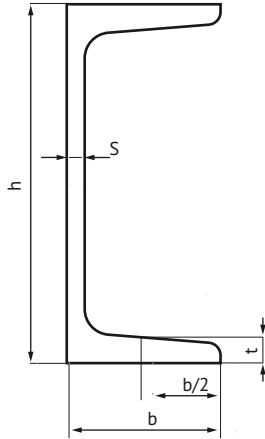

Profile type	Height, h	Flange width, b	Wall thickness, s	Flange thickness, t	Inner radius, r1	Edge radius, r2	Weight of 1 m, kg
U 80	80	45	6,0	8,0	8,0	4,0	8,64
U 100	100	50	6,0	8,5	8,5	4,5	10,6
U 120	120	55	7,0	9,0	9,0	4,5	13,4
U 140	140	60	7,0	10,0	10,0	5,0	16,0
U 160	160	65	7,5	10,5	10,5	5,5	18,8
U 180	180	70	8,0	11,0	11,0	5,5	22,0
U 200	200	75	8,5	11,5	11,5	6,0	25,3
U 220	220	80	9,0	12,5	12,5	6,5	29,4
U 240	240	85	9,5	13,0	13,0	6,5	33,2
U 260	260	90	10	14,0	14,0	7,0	37,9
U 280	280	95	10	15,0	15,0	7,5	41,8
U 300	300	100	10,0	16,0	16,0	8,0	46,2

Profile type	Normative document for technical requirements	Steel grade	Normative document for chemical composition	Product length
8П-30П	TU U 24.1-05393056-003:2020	Cr3nc/cn, 09Г2С	DSTU 2651:2005 GOST 380-2005 DSTU 8541:2015	Specified length 6, 9, 12 m
UPE 80-300 U 80-300	DIN 1026-2:2002 EN 10279:2000 DIN 1026-1:2009 EN 10279:2000	S235, S275, S355	EN 10025-2:2019	Specified length 6, 9, 12 m

Equal angles acc. to EN 10056-1:2017

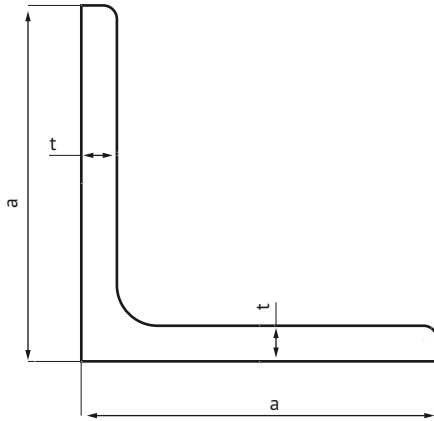

Angles	Leg width, a	Leg thickness, t	Transition radius	Edge radius	Weight of 1 m, kg
	Dimensions, mm				
75x75x6	75	6	9	4,5	6,85
75x75x8	75	8	9	4,5	8,99
80x80x8	80	8	10	5,0	9,63
80x80x10	80	10	10	5,0	11,9
90x90x7	90	7	11	5,5	9,61
90x90x8	90	8	11	5,5	10,9
90x90x9	90	9	11	5,5	12,2
90x90x10	90	10	11	5,5	13,4
100x100x8	100	8	12	6,0	12,2
100x100x10	100	10	12	6,0	15,0
100x100x12	100	12	12	6,0	17,8

Equal angles acc. to DSTU 2251:2018 (GOST 8509-93)

Angles	Leg width, a	Leg thickness, t	Transition radius	Edge radius	Weight of 1 m, kg
	Dimensions, mm				
75x75x5	75	5	9	3,0	5,80
75x75x6	75	6	9	3,0	6,89
75x75x7	75	7	9	3,0	7,96
75x75x8	75	8	9	3,0	9,02
75x75x9	75	9	9	3,0	10,07
80x80x5,5	80	5,5	9	3,0	6,78
80x80x6	80	6	9	3,0	7,36
80x80x7	80	7	9	3,0	8,51
80x80x8	80	8	9	3,0	9,65
90x90x6	90	6	10	3,3	8,33
90x90x7	90	7	10	3,3	9,64
90x90x8	90	8	10	3,3	10,93
90x90x9	90	9	10	3,3	12,20
100x100x6,5	100	6,5	12	4,0	10,06
100x100x7	100	7	12	4,0	10,79
100x100x8	100	8	12	4,0	12,25
100x100x10	100	10	12	4,0	15,10
100x100x12	100	12	12	4,0	17,90
125x125x8	125	8	14	4,6	15,46
125x125x10	125	10	14	4,6	19,10
125x125x12	125	12	14	4,6	22,68

Profile type	Нормативный документ на технические требования	Марка стали	Нормативный документ на химический состав	Длина проката
EN	EN 10056-1:2017 EN 10056-2:1993	S235, S275, S355	EN 10025-2:2019	Specified length 6, 9, 12 м
DSTU	DSTU 2251:2018	Ст3пс/сп, 09Г2С	DSTU 2651:2005 GOST 380-2005 DSTU 8541:2015	Specified length 6, 9, 12 м



**PRODUCTS
FOR INDUSTRIAL
APPLICATIONS**



Pit barring sections

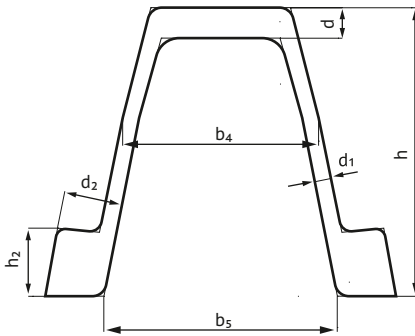

Profile type	h	b ₄	d	d ₁	h ₂	d ₂	b ₅	Theoretical weight of 1 m, kg
	Dimensions in mm							
СВП-17	94	84,6	8,5	5,7	23	19,7	91,5	17,1
СВП-22	110	83,5	11,0	6,2	25,5	22,5	99,5	21,9
СВП-27	123	83,5	13,0	7,1	29,0	25,0	99,5	27,0
СВП-33	137	91,5	14,5	7,9	32,0	27,5	110,0	33,39

Profile type	Normative document for technical requirements	Steel grade	Normative document for chemical composition	Product length
СВП-17	TU U 24.1-05393056-005:2021	Ст5nc/cп	DSTU 2651:2005 GOST 380-2005	Specified length 9-12 m; random length
СВП-22, СВП-27, СВП-33	TU U 24.1-05393056-287:2017	Ст5nc/cп	DSTU 2651:2005 GOST 380-2005	Specified length 9-12 m; random length

Hot-rolled steel sections for shares

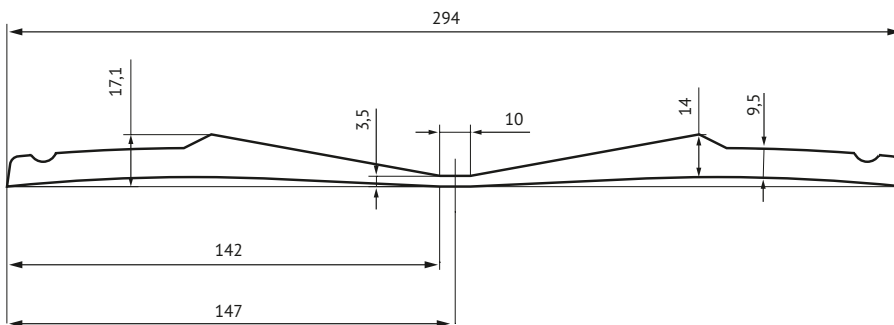

Profile type	Normative document for technical requirements	Steel grade	Normative document for chemical composition	Product length
142C _д	ТТ 05393056-2021	Л53	ТТ 05393056-2021	Multiple specified length



SEMIFINISHED PRODUCTS

Motor vehicle wheel rim sections

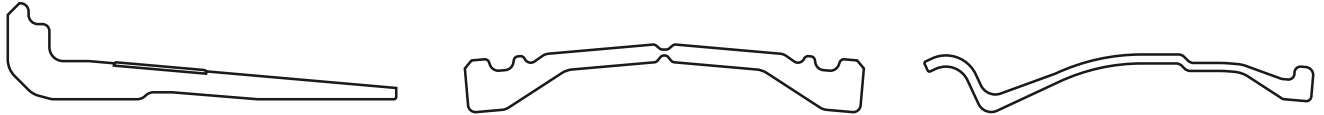

Profile type	Normative document for technical requirements	Steel grade	Normative document for chemical composition	Product length
Rim Pr.310-022	ТУ У 24.1-05393056-288:2020	10кп, 15кп	ДСТУ 7809:2015	Multiple specified length, random length
Rim Pr.310-023	ТУ У 24.1-05393056-288:2020	10кп, 15кп	ДСТУ 7809:2015	
Rim 7.0-20-05	ТУ У 24.1-05393056-288:2020	10кп, 15кп	ДСТУ 7809:2015	
Rim 7.5-20-03	ТУ У 24.1-05393056-288:2020	10кп, 15кп	ДСТУ 7809:2015	
Rim 6,0Б-20	ТУ У 24.1-05393056-288:2020	10кп, 15кп	ДСТУ 7809:2015	
Rim 8,5-20-04	ТУ У 24.1-05393056-288:2020	10кп, 15кп	ДСТУ 7809:2015	
Rim 228F-020-01	ТУ У 24.1-05393056-288:2020	10кп, 15кп	ДСТУ 7809:2015	
Rim 254-020-10	ТУ У 24.1-05393056-288:2020	10кп, 15кп	ДСТУ 7809:2015	
Rim Pr.7555-035	ТУ У 24.1-05393056-004:2021	15кп, 20	ДСТУ 7809:2015	
Rim Pr.755-022	ТУ У 24.1-05393056-004:2021	15кп, 20	ДСТУ 7809:2015	
Rim Pr.755-023	ТУ У 24.1-05393056-004:2021	15кп, 20	ДСТУ 7809:2015	
Rim 15.00-023-01	ТУ У 24.1-05393056-004:2021	15кп, 20	ДСТУ 7809:2015	



BUREAU VERITAS

Bureau Veritas Certification

PRIVATE JOINT-STOCK COMPANY “DNEPROVSK METALLURGICAL PLANT”

3, Mayakovsky Str., Dnipro, 49064, Ukraine

Bureau Veritas Certification Holding SAS – UK Branch certifies that the Management System of the above organisation has been audited and found to be in accordance with the requirements of the management system standards detailed below

ISO 14001:2015

Scope of certification

Design, production and realization of structural products and shape steel-rolled stocks, periodic and special profiles, billets and rails of rolling workshops No.1 and No.2.

Original cycle start date:	31 August 2020
Expiry date of previous cycle:	NA
Certification / Recertification Audit date:	NA
Certification / Recertification cycle start date:	29 August 2023

Subject to the continued satisfactory operation of the organisation’s Management System, this certificate expires on: **30 August 2026**

Certificate No. UA231060 Version: 1 Issue date: 29 August 2023

Olena Svyrydenko
Signed on behalf of BVCH SAS UK Branch



0008

*Certification body address: 5th Floor, 66 Prescott Street, London E1 8HG, United Kingdom
Local office: 5th floor, 28, Simon Petlyura St., Kyiv, 01032, UKRAINE*

Further clarifications regarding the scope and validity of this certificate, and the applicability of the management system requirements, please call: **+380 44 354 16 00**





BUREAU VERITAS

Bureau Veritas Certification

PRIVATE JOINT-STOCK COMPANY “DNEPROVSK METALLURGICAL PLANT”

3, Mayakovsky Str., Dnipro, 49064, Ukraine

Bureau Veritas Certification Holding SAS – UK Branch certifies that the Management System of the above organisation has been audited and found to be in accordance with the requirements of the management system standards detailed below

ISO 9001:2015

Scope of certification

Design, production and realization of structural products and shape steel-rolled stocks, periodic and special profiles, billets and rails of rolling workshops No.1 and No.2.

Original cycle start date:	08 September 2020
Expiry date of previous cycle:	NA
Certification / Recertification Audit date:	NA
Certification / Recertification cycle start date:	06 September 2023

Subject to the continued satisfactory operation of the organisation's Management System, this certificate expires on: **07 September 2026**

Certificate No. UA231067 Version: 1 Issue date: 06 September 2023



Olena Svyrydenko
Signed on behalf of BVCH SAS UK Branch



*Certification body address: 5th Floor, 66 Prescot Street, London E1 8HG, United Kingdom
Local office: 5th floor, 28, Simon Petlyura St., Kyiv, 01032, UKRAINE*

Further clarifications regarding the scope and validity of this certificate, and the applicability of the management system requirements, please call: +380 44 354 16 00



ZERTIFIKAT ♦ CERTIFICATE ♦ 認證證書 ♦ СЕРТИФИКАТ ♦ CERTIFICADO ♦ CERTIFICAT

F:\402014\402014\2017-04-01\PSAC_036_31020



CERTIFICATE OF CONFORMITY OF THE FACTORY PRODUCTION CONTROL

Registration number 1017 – CPR – 01.472.069/10/02/07/0, Revision No. 3

In compliance with Regulation (EU) No 305/2011 of the European Parliament and Council of 9 March 2011 laying down harmonised conditions for the marketing of construction products and repealing Council Directive 89/106/EEC, and in compliance with Commission Delegated Regulation (EU) No 568/2014, this certificate is issued for the construction product:

Hot rolled products of structural steels

– profile U, UPE and L

produced by:

**PRIVATE JOINT STOCK COMPANY
„DNEPROVSK METALLURGICAL PLANT“**

DCH

3, Mayakovsky Str., 49064 Dnipro, Ukraine
Company Registration No.: 05393056

and produced in the manufacturing plant:
3, Mayakovsky Str., 49064 Dnipro, Ukraine

This certificate attests that all provisions concerning the assessment and verification of constancy of performance in the context of the system 2+ in the sense of Annex V, 1.3 of CPR and described in Annex ZA of the standard were asserted

EN 10025-1:2004

and certifies that

**the factory production control system fulfils all
the designated requirements**

This certificate was first issued on 08.04.2010 as a certificate according to the CPD and remains valid, as long as the test methods and/or factory production control requirements included in the harmonized standard, used to assess the performance of the declared characteristics, do not change, and the product, and/or the manufacturing conditions and technological procedures in the plant are not modified significantly.

This certificate is a revision No. 3 of the certificate No. 1017 – CPD – 01.472.069/10/02/07/0, issued 08.04.2010.

Prague, 09.07.2018



on behalf of Notified Body 1017
Pavla Nerandžicová
Head of Certification Department

TÜV SÜD Czech s.r.o. • Novodvorská 994 • 142 21 Prague 4 • Czech Republic • certification@tuv-sud.cz

TÜV®